



Department of Engineering for Innovation
University of Salento
Lecce, Italy



Virtual and Augmented Reality Applications

Lucio Tommaso De Paolis

Augmented and Virtual Reality Laboratory (AVR Lab)



Collision Detection

Examples of Collision Detection

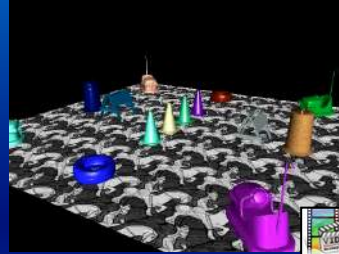
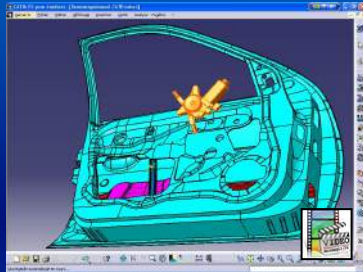

Examples of Collision Detection

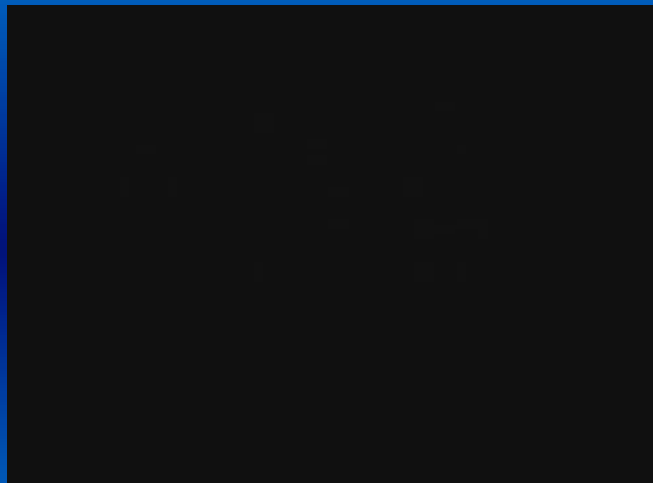

Tests

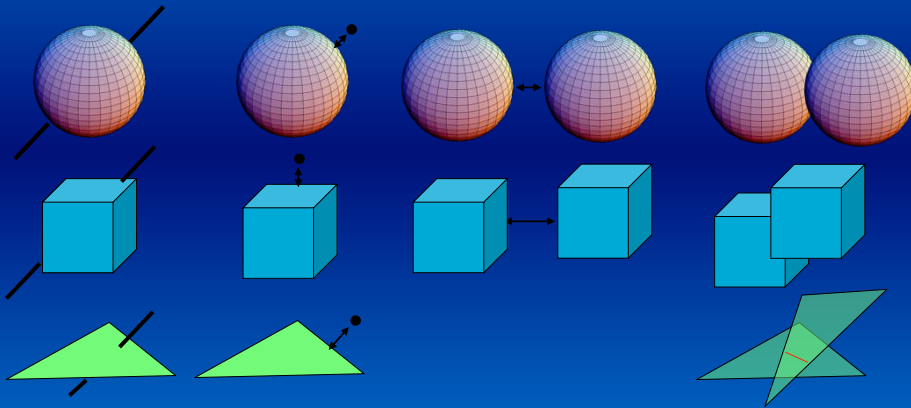

5

Bounding Volume Hierarchies



6

Bounding Volume Hierarchies

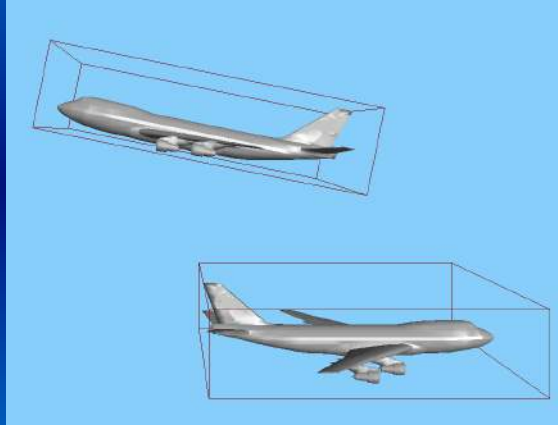

7

Bounding Volume Hierarchies

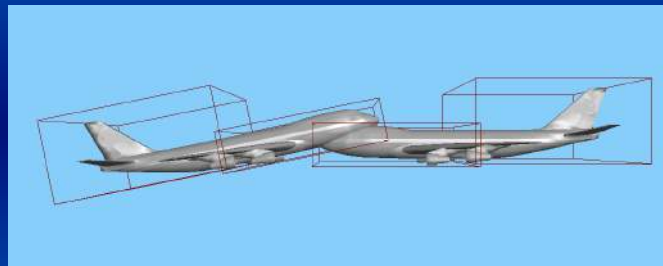

8

Bounding Volumes

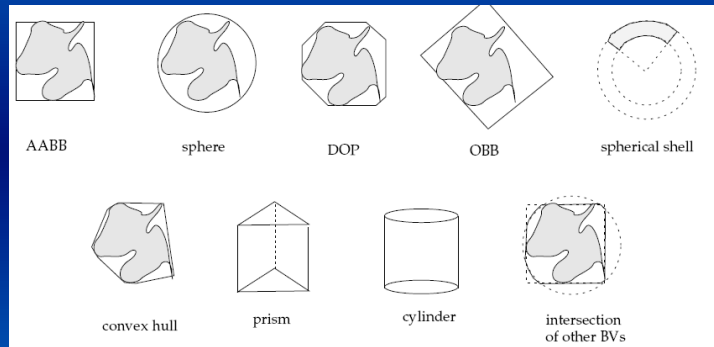

9

Bounding Volume Hierarchies



10

Axis Aligned Bounding Boxes

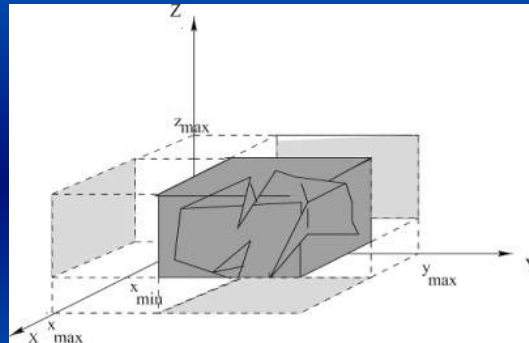

11

Bounding Spheres

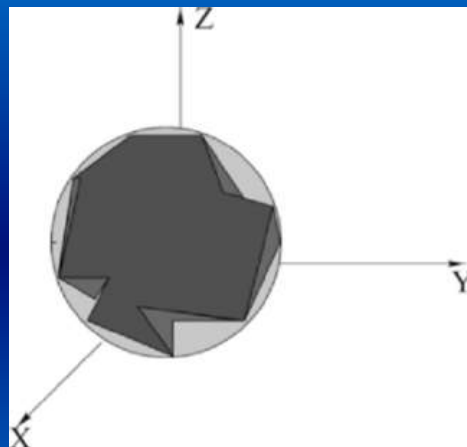

12

Oriented Bounding Boxes

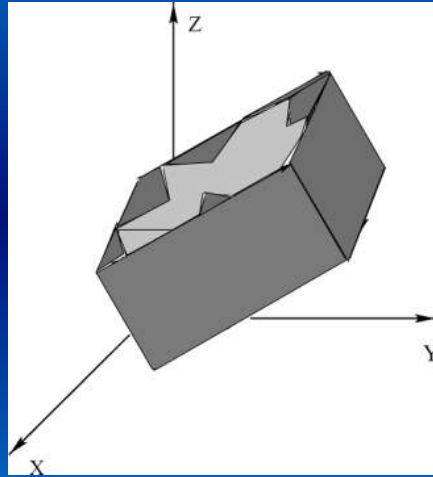

13

Discrete Orientation Polytopes

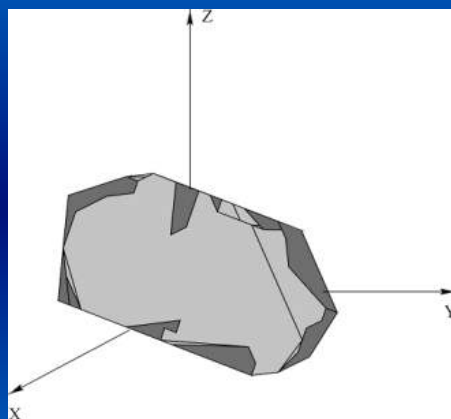

14

Bounding Spheres

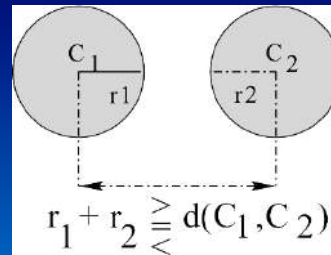
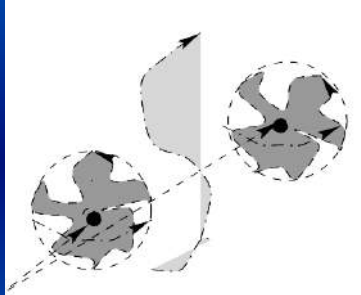

15

Bounding Spheres Hierarchies

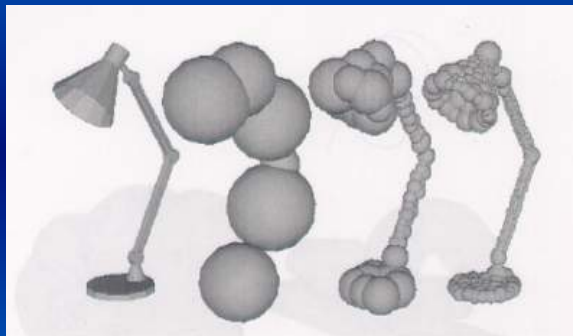

16

Bounding Spheres Hierarchies

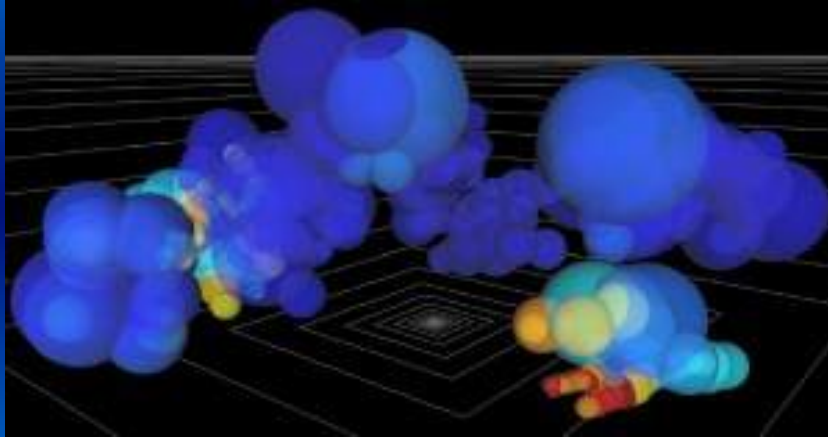

17

Algorithms of Collision Detection

RAPID (1997)

Polygon soup, OBBTree, oggetti deformabili
www.cs.unc.edu/geom/OBB/OBBT.html

OPCODE OPTimized COLLision Detection

Versione moderna e alleggerita di RAPID (usato da ODE)
<http://www.codercorner.com/Opcode.htm>

QHULL

Sistema per la decomposizione di poliedri in poliedri convessi
www.comlab.ox.ac.uk/oucl/users/stephen.cameron/distance.html

I-Collide

Collision detection tra poliedri convessi
http://www.cs.unc.edu/~geom/I_COLLIDE/index.html

V-Collide (1998)

Sfrutta RAPID, su qualunque modello poligonale
http://www.cs.unc.edu/~geom/V_COLLIDE/

SOLID (Jan 2004)

Libreria generica per la collision, varie rappresentazioni e deformabile
<http://www.win.tue.nl/~ajno/solid/>

Sphere Tree Construction Kit

Un tool per costruire gerarchie di sfere
<http://isg.cs.tcd.ie/spheretree/>

18



Department of Engineering for Innovation
University of Salento
Lecce, Italy



Lucio Tommaso De Paolis

lucio.depaolis@unisalento.it

www.avr.unisalento.it